

16 mm Square Encoders

Type: **EVEP/EVEQ**

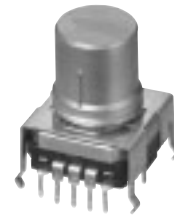

■ Features

- Good operational feel
- Long life due to high click torque
- Shaft wobble : 0.1 mm max.

■ Recommended Applications

- Centralized control of automotive audio equipment, navigation systems, and air conditioners.

■ Explanation of Part Numbers

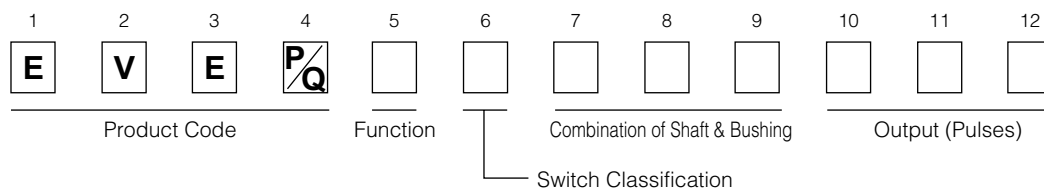

■ Specifications

		EVEP	EVEQ
Mechanical	Rotation Angle	360 ° (Endless)	
	Shaft Pull/Push Strength	100 N min.	
	Shaft Wobble	0.1 mm max.(Length form mounting surface : 21.5 mm) (50 mN·m is applied on the point 2 mm from the shaft tip)	
	Rotation Torque	25 mN·m max.	
	Detents	16 points	32 points
Electrical	Output Signals	Phase A and B	
	Resolution	8 pulses/ 360 °	16 pulses/ 360 °
	Rating	1 mA 10 Vdc (at each bit)	
	Contact Resistance	1 Ω max.	
	Chattering	5 ms max.	
	Insulation Resistance	50 MΩ min. (at 250 Vdc)	
	Dielectric Withstanding Voltage	300 Vac for 1 minute	
Switch Part	Bouncing	5 ms max.	
	Type	SPST Push-on	
	Rating	20 mA 16 Vdc	
	Contact Resistance	100 mΩ max.	
	Operating Force	6 N	
Endurance	Travel	0.5 mm	
	Rotation Life (Encoder)	1000000 cycles min.	30000 cycles min.
	Operating Life (Switch)	1000000 cycles min.	30000 cycles min.
Minimum Quantity/Packing Unit		50 pcs. (Tray Pack)	
Quantity/Carton		200 pcs.	

■ Dimensions in mm (not to scale)

EVEP/EVEQ

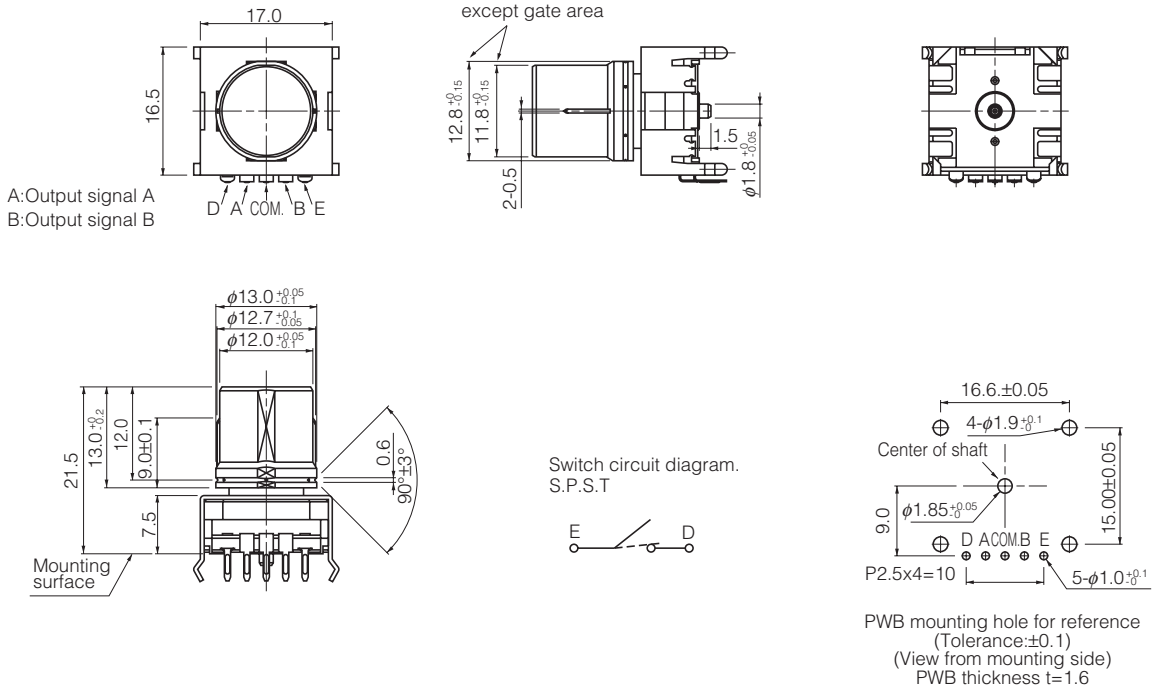

■ Phase Difference

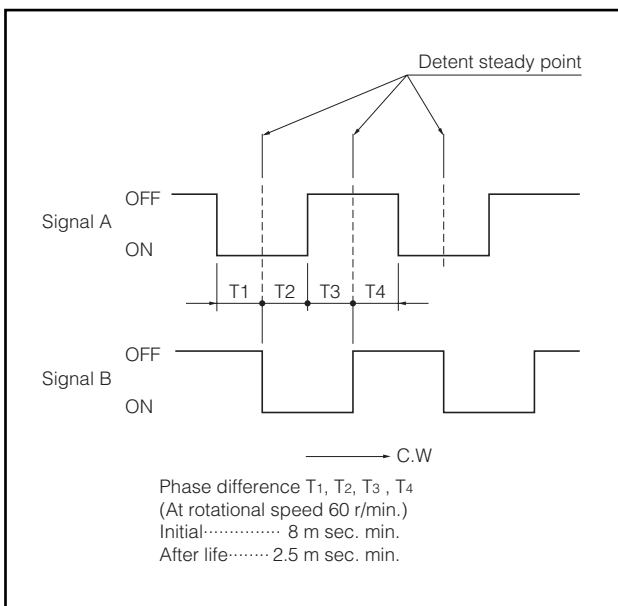

■ Test Circuit Diagram

