

### 15A HIGH SNAP SWITCHES TOGGLE, ROCKER AND PUSH-BUTTON TYPES

### T-15 SERIES SWITCHES

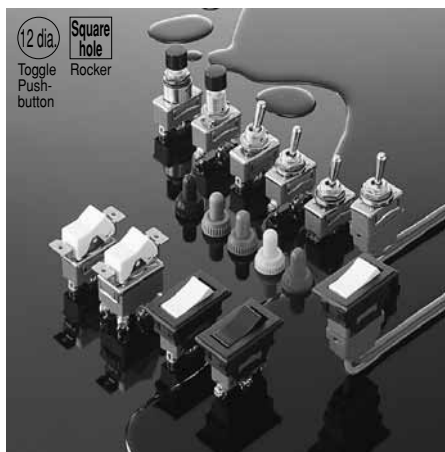

RoHS compliant

### FEATURES

#### 1. Series now includes rocker and push-button switches.

Based on the well-established T-15 Series switch, the mechanism is kept as is and a rocker type and push-button type have been added to the series. (Note that the push-button type is rated at 10 A.)

#### 2. Sealed type added for use in different environments.

Packing is used where parts join and an O-ring is used to seal moving parts. New to the series, this type can be used in harsh environments such as those with water, oil, dust, and gas.

##### • Panel-sealed type

Entry of water, oil, dust and gas from the front of the panel is prevented.

(Panel front: IP67\*; Inside of panel: IP40)

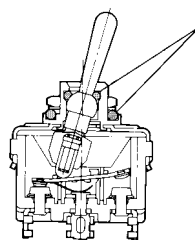

##### • Terminal-sealed type

Both switch body and terminals have been sealed to protect from dust and gas that enters from the panel.

(Panel front: IP67\*; Inside of panel: IP60)

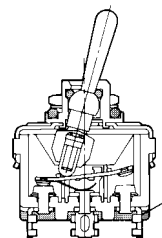

##### • Wire lead type

Furthermore, a cover is provided for the terminals to keep out water and oil that enters from the panel.

(Panel front: IP67\*; Inside of panel: IP67)

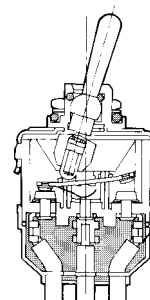

Remark: The asterisk in "Panel front: IP67\*" means this only applies to toggle and push-button types.

The panel surface for the rocker type is IP64. Please see NOTES 1 and 2 regarding use of the sealed type.

#### 3. Rubber cap also available in silicon type for excellent weather resistance.

• 5 colors available so you can distinguish switches by purpose.

<Example>

Black: For main power supply

Grey: For setting and switching

Red: For resetting

• With a usable ambient temperature range of  $-25^{\circ}\text{C}$  to  $+85^{\circ}\text{C}$ , use is possible in environments that require resistance against heat and cold.

### ASSORTMENT

Kind of actuator	Standard type	Sealed type			Number of pole				Shape of terminal			
		Panel-sealed type	Terminal-sealed type	Wire leads type	1P	2P	3P	4P	Solder terminal	Screw terminal	.250 Quick-connect terminal	Wire lead
Toggle type	Available	Available	Available	Available	Available	Available	Available*1	Available*1	Available	Available	Available*1	Available*2
Rocker type	Available	Available	Available	Available	Available	Available	—	—	Available	Available	—	Available*2
Push-button type	Available	Available	—	—	Available	Available	—	—	Available	Available	—	—

Remarks: \*1: Only standard type

\*2: Only wire leads type

## TOGGLE PRODUCT TYPES



### 1. Standard type

#### 1) Solder terminal and .250 Quick-connect terminal

Number of poles	Kind of operation < >: Momentary position	Solder terminal	.250 Quick-connect terminal
		Product No.	Product No.
1-pole	ON-OFF	T115A-F	T115A-AF
	ON-ON	T115D-F	T115D-AF
	ON-OFF-ON	T115E-F	T115E-AF
	ON-<ON>	T115F-F	T115F-AF
	<ON>-OFF-<ON>	T115G-F	T115G-AF
	ON-OFF-<ON>	T115H-F	T115H-AF
2-pole	ON-OFF	T215K-F	T215K-AF
	ON-ON	T215N-F	T215N-AF
	ON-OFF-ON	T215P-F	T215P-AF
	ON-<ON>	T215R-F	T215R-AF
	<ON>-OFF-<ON>	T215S-F	T215S-AF
	ON-OFF-<ON>	T215T-F	T215T-AF
3-pole	ON-OFF	T315K-F	T315K-AF
	ON-ON	T315N-F	T315N-AF
	ON-OFF-ON	T315P-F	T315P-AF
4-pole	ON-OFF	T415K-F	T415K-AF
	ON-ON	T415N-F	T415N-AF
	ON-OFF-ON	T415P-F	T415P-AF

#### 2) Screw terminal

Number of poles	Kind of operation < >: Momentary position	Screw terminal
		Product No.
1-pole	ON-OFF	T115A-SF
	ON-ON	T115D-SF
	ON-OFF-ON	T115E-SF
	ON-<ON>	T115F-SF
	<ON>-OFF-<ON>	T115G-SF
	ON-OFF-<ON>	T115H-SF
2-pole	ON-OFF	T215K-SF
	ON-ON	T215N-SF
	ON-OFF-ON	T215P-SF
	ON-<ON>	T215R-SF
	<ON>-OFF-<ON>	T215S-SF
	ON-OFF-<ON>	T215T-SF
3-pole	ON-OFF	T315K-SF
	ON-ON	T315N-SF
	ON-OFF-ON	T315P-SF
4-pole	ON-OFF	T415K-SF
	ON-ON	T415N-SF
	ON-OFF-ON	T415P-SF

Remark: Standard installation accessories are included with the product.

## 2. Panel-sealed type

### 1) Solder terminal

Number of poles	Kind of operation < >: Momentary position	Solder terminal
		Product No.
1-pole	ON-OFF	TP115A-F
	ON-ON	TP115D-F
	ON-OFF-ON	TP115E-F
	ON-<ON>	TP115F-F
	<ON>-OFF-<ON>	TP115G-F
	ON-OFF-<ON>	TP115H-F
2-pole	ON-OFF	TP215K-F
	ON-ON	TP215N-F
	ON-OFF-ON	TP215P-F
	ON-<ON>	TP215R-F
	<ON>-OFF-<ON>	TP215S-F
	ON-OFF-<ON>	TP215T-F

### 2) Screw terminal

Number of poles	Kind of operation < >: Momentary position	Screw terminal
		Product No.
1-pole	ON-OFF	TP115A-SF
	ON-ON	TP115D-SF
	ON-OFF-ON	TP115E-SF
	ON-<ON>	TP115F-SF
	<ON>-OFF-<ON>	TP115G-SF
	ON-OFF-<ON>	TP115H-SF
2-pole	ON-OFF	TP215K-SF
	ON-ON	TP215N-SF
	ON-OFF-ON	TP215P-SF
	ON-<ON>	TP215R-SF
	<ON>-OFF-<ON>	TP215S-SF
	ON-OFF-<ON>	TP215T-SF

Remark: Of the standard installation accessories that come with the product, the front hex nut and lock washer are included.

## 3. Terminal-sealed type

### 1) Solder terminal

Number of poles	Kind of operation < >: Momentary position	Solder terminal
		Product No.
1-pole	ON-OFF	TD115A-F
	ON-ON	TD115D-F
	ON-OFF-ON	TD115E-F
	ON-<ON>	TD115F-F
	<ON>-OFF-<ON>	TD115G-F
	ON-OFF-<ON>	TD115H-F
2-pole	ON-OFF	TD215K-F
	ON-ON	TD215N-F
	ON-OFF-ON	TD215P-F
	ON-<ON>	TD215R-F
	<ON>-OFF-<ON>	TD215S-F
	ON-OFF-<ON>	TD215T-F

Remark: Of the standard installation accessories that come with the product, the front hex nut and lock washer are included.

2) Screw terminal

Number of poles	Kind of operation < >: Momentary position	Screw terminal
		Product No.
1-pole	ON-OFF	TD115A-SF
	ON-ON	TD115D-SF
	ON-OFF-ON	TD115E-SF
	ON-<ON>	TD115F-SF
	<ON>-OFF-<ON>	TD115G-SF
	ON-OFF-<ON>	TD115H-SF
2-pole	ON-OFF	TD215K-SF
	ON-ON	TD215N-SF
	ON-OFF-ON	TD215P-SF
	ON-<ON>	TD215R-SF
	<ON>-OFF-<ON>	TD215S-SF
	ON-OFF-<ON>	TD215T-SF

Remark: Of the standard installation accessories that come with the product, the front hex nut and lock washer are included.

4. Wire lead type

Number of poles	Kind of operation < >: Momentary position	Wire lead type
		Product No.
1-pole	ON-OFF	TC115A-F
	ON-ON	TC115D-F
	ON-OFF-ON	TC115E-F
	ON-<ON>	TC115F-F
	<ON>-OFF-<ON>	TC115G-F
	ON-OFF-<ON>	TC115H-F
2-pole	ON-OFF	TC215K-F
	ON-ON	TC215N-F
	ON-OFF-ON	TC215P-F
	ON-<ON>	TC215R-F
	<ON>-OFF-<ON>	TC215S-F
	ON-OFF-<ON>	TC215T-F

Remarks: 1. Standard installation accessories are included with the product.

2. 600 V vinyl wire (VSF, thick: 2 mm<sup>2</sup>, length: 200 mm) is used. Please inquire about type and different length of lead wire.

5. Accessories

1) Installation accessories (Repair parts)

Product name	Standard installation accessories				Optional installation accessories
	Front hex nut (Nickel plated)	Back hex nut (Uni-chrome plated)	Keying washer	Lock washer	Front Knurl nut (Nickel plated)
Dimensions (mm)					
Part No.	AJ3081	AJ3082	AJ3083	AJ3084	AJ3080

Remark: A selling unit of each accessory is 10 pieces.

• Using the different rubber caps

We recommend silicon rubber and EP rubber caps for the following applications.

1) Silicon rubber caps

- When it is necessary to differentiate by color.
- When using in applications that require resistance to heat and cold. Ambient temperature: -25°C to +85°C (EP rubber type is 0°C to +40°C.)
- When compactness is required.

2) EP rubber type

When cost is the primary consideration.

## 2) Accessories (Option)

Product name	Indication plate (aluminum)*3		Rubber cap*1, 2, 4	
	ON-OFF	ON-ON	EP rubber type	Silicone rubber type
Dimensions (mm)				
Part No.	WD1901	WD1902	WD1911	WD1811*

- Remarks: 1. The asterisk in the part number WD1811\* for the silicon rubber type rubber cap is where the letter representing the color should be inserted. (B: black; R: red; Z: grey; Y: yellow; G: green.)  
 2. EP rubber cap is available in black only.  
 3. Letters on the display panel are aluminum colored and the area surrounding the letters is black.  
 4. Indication plate and rubber cap are compatible with the T-15 series switch, T-10 series switch, and T-03/T-06 series switches (when plate thickness is 2.7 mm or less).

## ROCKER PRODUCT TYPES



## 1. Standard type

## 1) Solder terminal, without indication on actuator

Number of poles	Kind of operation < >: Momentary position	Solder terminal
		Product No.
1-pole	ON-OFF	TR115A-*F
	ON-ON	TR115D-*F
	ON-OFF-ON	TR115E-*F
	ON-<ON>	TR115F-*F
	<ON>-OFF-<ON>	TR115G-*F
	ON-OFF-<ON>	TR115H-*F
2-pole	ON-OFF	TR215K-*F
	ON-ON	TR215N-*F
	ON-OFF-ON	TR215P-*F
	ON-<ON>	TR215R-*F
	<ON>-OFF-<ON>	TR215S-*F
	ON-OFF-<ON>	TR215T-*F

## 2) Screw terminal, without indication on actuator

Number of poles	Kind of operation < >: Momentary position	Screw terminal
		Product No.
1-pole	ON-OFF	TR115A-S*F
	ON-ON	TR115D-S*F
	ON-OFF-ON	TR115E-S*F
	ON-<ON>	TR115F-S*F
	<ON>-OFF-<ON>	TR115G-S*F
	ON-OFF-<ON>	TR115H-S*F
2-pole	ON-OFF	TR215K-S*F
	ON-ON	TR215N-S*F
	ON-OFF-ON	TR215P-S*F
	ON-<ON>	TR215R-S*F
	<ON>-OFF-<ON>	TR215S-S*F
	ON-OFF-<ON>	TR215T-S*F

## 3) Solder terminal, with ON-OFF indication on actuator

Number of poles	Kind of operation < >: Momentary position	Solder terminal
		Product No.
1-pole	ON-OFF	TR115A-*F
2-pole	ON-OFF	TR215K-*F

Remark: Please specify the actuator color by replacing the asterisk in the product number with appropriate letter. (B: black; W: white; R: red; Z: dark grey)

## 4) Screw terminal, with ON-OFF indication on actuator

Number of poles	Kind of operation < >: Momentary position	Screw terminal
		Product No.
1-pole	ON-OFF	TRP115A-S*F
2-pole	ON-OFF	TRP215K-S*F

Remark: Please specify the actuator color by replacing the asterisk in the product number with appropriate letter. (B: black; W: white; R: red; Z: dark grey)

## 2. Panel-sealed type

## 1) Solder terminal, without indication on actuator

Number of poles	Kind of operation < >: Momentary position	Solder terminal
		Product No.
1-pole	ON-OFF	TRP115A-*F
	ON-ON	TRP115D-*F
	ON-OFF-ON	TRP115E-*F
	ON-<ON>	TRP115F-*F
	<ON>-OFF-<ON>	TRP115G-*F
	ON-OFF-<ON>	TRP115H-*F
2-pole	ON-OFF	TRP215K-*F
	ON-ON	TRP215N-*F
	ON-OFF-ON	TRP215P-*F
	ON-<ON>	TRP215R-*F
	<ON>-OFF-<ON>	TRP215S-*F
	ON-OFF-<ON>	TRP215T-*F

## 2) Screw terminal, without indication on actuator

Number of poles	Kind of operation < >: Momentary position	Screw terminal
		Product No.
1-pole	ON-OFF	TRP115A-S*F
	ON-ON	TRP115D-S*F
	ON-OFF-ON	TRP115E-S*F
	ON-<ON>	TRP115F-S*F
	<ON>-OFF-<ON>	TRP115G-S*F
	ON-OFF-<ON>	TRP115H-S*F
2-pole	ON-OFF	TRP215K-S*F
	ON-ON	TRP215N-S*F
	ON-OFF-ON	TRP215P-S*F
	ON-<ON>	TRP215R-S*F
	<ON>-OFF-<ON>	TRP215S-S*F
	ON-OFF-<ON>	TRP215T-S*F

## 3) Solder terminal, with ON-OFF indication on actuator

Number of poles	Kind of operation < >: Momentary position	Solder terminal
		Product No.
1-pole	ON-OFF	TRP115A-*1F
2-pole	ON-OFF	TRP215K-*1F

## 4) Screw terminal, with ON-OFF indication on actuator

Number of poles	Kind of operation < >: Momentary position	Screw terminal
		Product No.
1-pole	ON-OFF	TRP115A-S*1F
2-pole	ON-OFF	TRP215K-S*1F

Remark: Please specify the actuator color by replacing the asterisk in the product number with appropriate letter. (B: black; W: white; R: red; Z: dark grey)

### 3. Terminal-sealed type

#### 1) Solder terminal, without indication on actuator

Number of poles	Kind of operation < >: Momentary position	Solder terminal
		Product No.
1-pole	ON-OFF	TRD115A-*F
	ON-ON	TRD115D-*F
	ON-OFF-ON	TRD115E-*F
	ON-<ON>	TRD115F-*F
	<ON>-OFF-<ON>	TRD115G-*F
	ON-OFF-<ON>	TRD115H-*F
2-pole	ON-OFF	TRD215K-*F
	ON-ON	TRD215N-*F
	ON-OFF-ON	TRD215P-*F
	ON-<ON>	TRD215R-*F
	<ON>-OFF-<ON>	TRD215S-*F
	ON-OFF-<ON>	TRD215T-*F

#### 2) Screw terminal, without indication on actuator

Number of poles	Kind of operation < >: Momentary position	Screw terminal
		Product No.
1-pole	ON-OFF	TRD115A-S*F
	ON-ON	TRD115D-S*F
	ON-OFF-ON	TRD115E-S*F
	ON-<ON>	TRD115F-S*F
	<ON>-OFF-<ON>	TRD115G-S*F
	ON-OFF-<ON>	TRD115H-S*F
2-pole	ON-OFF	TRD215K-S*F
	ON-ON	TRD215N-S*F
	ON-OFF-ON	TRD215P-S*F
	ON-<ON>	TRD215R-S*F
	<ON>-OFF-<ON>	TRD215S-S*F
	ON-OFF-<ON>	TRD215T-S*F

#### 3) Solder terminal, with ON-OFF indication on actuator

Number of poles	Kind of operation < >: Momentary position	Solder terminal
		Product No.
1-pole	ON-OFF	TRD115A-*1F
2-pole	ON-OFF	TRD215K-*1F

#### 4) Screw terminal, with ON-OFF indication on actuator

Number of poles	Kind of operation < >: Momentary position	Screw terminal
		Product No.
1-pole	ON-OFF	TRD115A-S*1F
2-pole	ON-OFF	TRD215K-S*1F

Remark: Please specify the actuator color by replacing the asterisk in the product number with appropriate letter. (B: black; W: white; R: red; Z: dark grey)

**4. Wire lead type**

1) Without indication on actuator

Number of poles	Kind of operation < >: Momentary position	Wire lead type
		Product No.
1-pole	ON-OFF	TRC115A-*F
	ON-ON	TRC115D-*F
	ON-OFF-ON	TRC115E-*F
	ON-<ON>	TRC115F-*F
	<ON>-OFF-<ON>	TRC115G-*F
	ON-OFF-<ON>	TRC115H-*F
2-pole	ON-OFF	TRC215K-*F
	ON-ON	TRC215N-*F
	ON-OFF-ON	TRC215P-*F
	ON-<ON>	TRC215R-*F
	<ON>-OFF-<ON>	TRC215S-*F
	ON-OFF-<ON>	TRC215T-*F

2) With ON-OFF indication on actuator

Number of poles	Kind of operation < >: Momentary position	Wire lead type
		Product No.
1-pole	ON-OFF	TRC115A-*1F
2-pole	ON-OFF	TRC215K-*1F

Remarks: 1. Please specify the actuator color by replacing the asterisk in the product number with appropriate letter. (B: black; W: white; R: red; Z: dark grey)  
 2. 600 V vinyl wire (VSF, thick: 2 mm<sup>2</sup>, length: 200 mm) is used. Please inquire about type and different length of lead wire.

**PUSH-BUTTON PRODUCT TYPES**



**1. Standard type**

1) Solder terminal

Number of poles	Kind of operation	Solder terminal
		Product No.
1-pole	Momentary	TB110F-F
	Alternate	TB115D-F
2-pole	Momentary	TB210R-F
	Alternate	TB215N-F

2) Screw terminal

Number of poles	Kind of operation	Screw terminal
		Product No.
1-pole	Momentary	TB110F-SF
	Alternate	TB115D-SF
2-pole	Momentary	TB210R-SF
	Alternate	TB215N-SF

Remarks: 1. Please use switch body with a color cap (sold separately).  
 2. Standard installation accessories are included with the product.

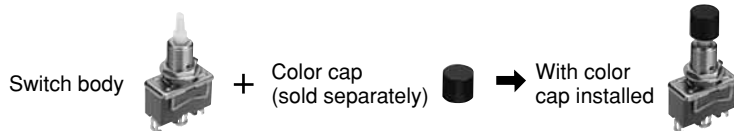



## 2. Panel-sealed type

### 1) Solder terminal

Number of poles	Kind of operation	Solder terminal
		Product No.
1-pole	Momentary	TBP110F-F
	Alternate	TBP115D-F
2-pole	Momentary	TBP210R-F
	Alternate	TBP215N-F

### 2) Screw terminal

Number of poles	Kind of operation	Screw terminal
		Product No.
1-pole	Momentary	TBP110F-SF
	Alternate	TBP115D-SF
2-pole	Momentary	TBP210R-SF
	Alternate	TBP215N-SF

Remarks: 1. Please use switch body with a color cap (sold separately).  
2. Standard installation accessories are included with the product.

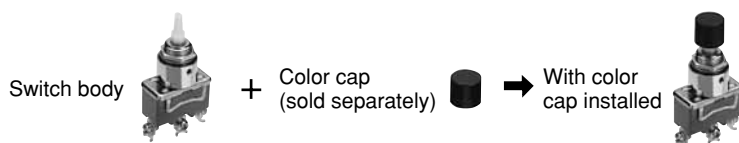

## 3. Color cap for push-button (Option)

Product name	Color cap (sold separately)
Dimensions (mm)	
Part No.	WDB1821*

Remark: Please specify the color cap color by replacing the asterisk in the part number with appropriate letter  
(B: black; W: white; R: red; Z: dark grey; H: light grey; Y: yellow; G: green; L: blue).

## 4. Installation accessories (Repair parts)

Product name	Standard installation accessories				Optional installation accessories
	Front hex nut (Nickel plated)	Back hex nut (Uni-chrome plated)	Keying washer	Lock washer	Front Knurl nut (Nickel plated)
Dimensions (mm)					
Part No.	AJ3081	AJ3082	AJ3083	AJ3084	AJ3080

Remark: A selling unit of each accessory is 10 pieces.

## SPECIFICATIONS

### 1. Contact rating

#### 1) Toggle type and Rocker type

Kind of load	AC	DC
Resistive load	15A 250V	0.5A 250V, 0.9A 125V, 15A 30V
Inductive load	15A 250V (Power factor: 0.6)	0.3A 250V (Time constant: 8 ms), 0.5A 125V (Time constant: 8 ms) 15A 30V (Time constant: 8 ms)
Lamp load (incandescent)	400W 100V, 800W 200V, Inrush current: Max. 40 A	7A 30V
Motor load	400 W 125 V (single phase), 550 W 250 V (single phase), 750 W 250 V (three-phase)	—

#### 2) Push-button type (momentary)

Kind of load	AC	DC
Resistive load	10A 250V	0.4A 250V, 0.8A 125V, 8A 30V

#### 3) Push-button type (alternate)

Kind of load	AC	DC
Resistive load	15A 250V	0.5A 250V, 0.9A 125V, 15A 30V

### 2. Characteristics

Shape of actuator	Toggle type		Rocker type	Push-button type
Protection grade *1: IP40 *2: IP64 *3: IP67	Standard type (*1)	Panel-sealed type (*3) Terminal-sealed type (*3) Wire leads type (*3)	Standard type (*1) Panel-sealed type (*2) Terminal-sealed type (*2) Wire leads type (*2)	Standard type (*1) Panel-sealed type (*3)
Mechanical expected life	1-pole and 2-pole: Min. $10^5$ 3-pole and 4-pole: Min. $8.5 \times 10^4$	Min. $5 \times 10^4$ (20 cpm) ON-OFF, ON-ON, ON-OFF-ON, Min. $3 \times 10^4$ (20 cpm) ON-(ON), (ON)-OFF-(ON), ON-OFF-(ON)	Min. $3 \times 10^4$ (20 cpm)	
Electrical expected life (10 cpm)	Standard and panel-sealed types: Min. $3 \times 10^4$ Terminal-sealed and wire leads types: Min. $1.5 \times 10^4$		Standard type: Min. $3 \times 10^4$ Panel-sealed, terminal-sealed and wire leads types: Min. $10^4$	Min. $10^4$
Dielectric strength	1500 Vrms (at detection current: 10mA)			
Insulation resistance	Min. 100 M $\Omega$ (at 500 V DC measured by insulation resistive meter)			
Contact resistance	Initial, Max. 10 m $\Omega$ (By voltage drop at 1 A, 2 to 4 V DC) Wire leads type only: Initial, Max. 30 m $\Omega$ (By voltage drop at 1 A, 2 to 4 V DC)			
Actuator strength	112.7N for 1 min. (For operating direction)			
Vibration resistance	10 to 55 Hz at double amplitude of 1.5 mm (contact opening: Max. 10 ms)			
Terminal strength (static load)	24.5N for 1 min.			
Ambient temperature	-25°C to +70°C (Not freezing below 0°C)			
Contact material	AgZnO alloy			

### DATA (Electrical life, For toggle standard type)

Tested condition: 250 V AC, Power factor: 0.6 and 10 cpm

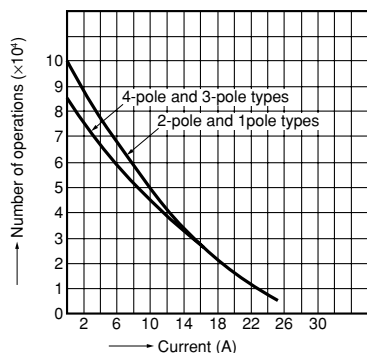

# TOGGLE TYPE DIMENSIONS

The CAD data of the products with a **CAD Data** mark can be downloaded from: <http://industrial.panasonic.com/ac/e/>

mm General tolerance: ±0.5

## 1. Standard type 1) Solder terminal

**CAD Data**

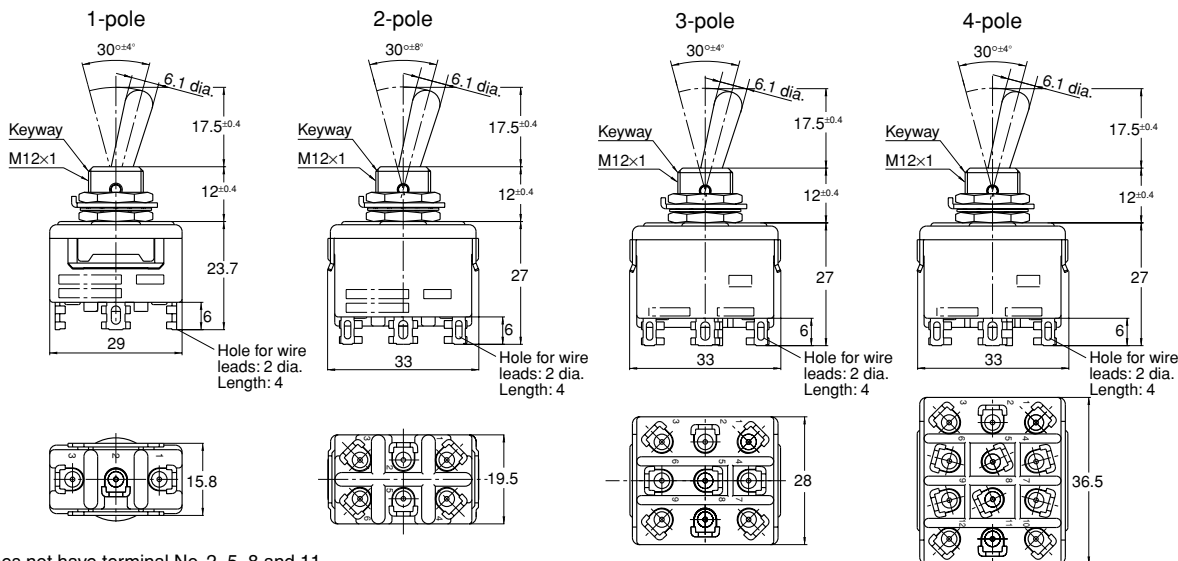

Remark: ON-OFF type does not have terminal No. 2, 5, 8 and 11.

## 2) Screw terminal (M3.5)

**CAD Data**

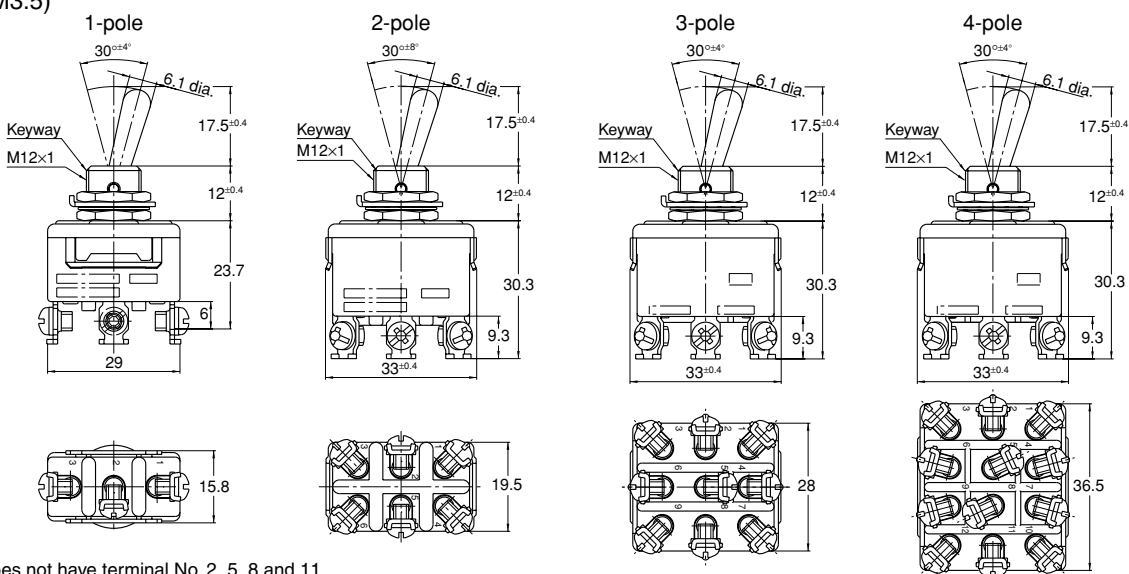

Remark: ON-OFF type does not have terminal No. 2, 5, 8 and 11.

## 3) .250 Quick-connect terminal

**CAD Data**

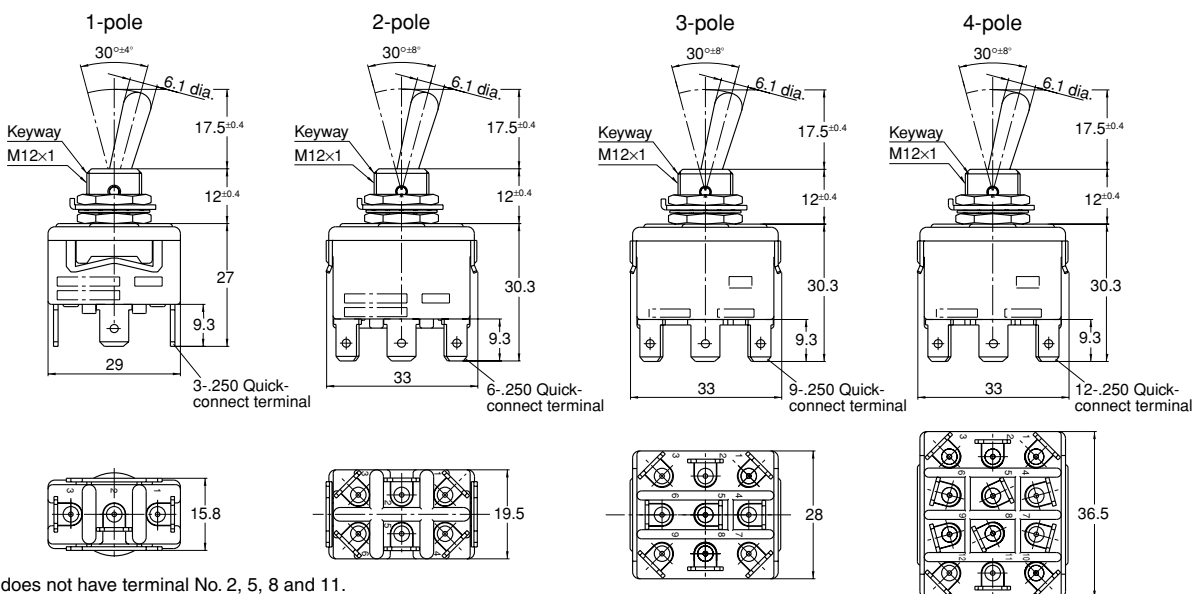

Remark: 1. ON-OFF type does not have terminal No. 2, 5, 8 and 11.  
2. There is no through-hole on .250 Quick-connect terminals.

2. Panel-sealed type

1) Solder terminal

CAD Data

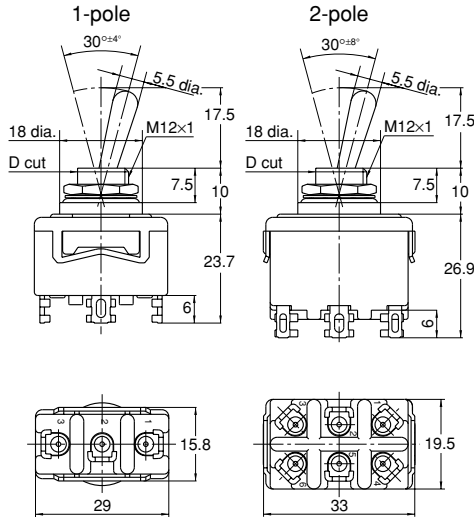

2) Screw terminal (M3.5)

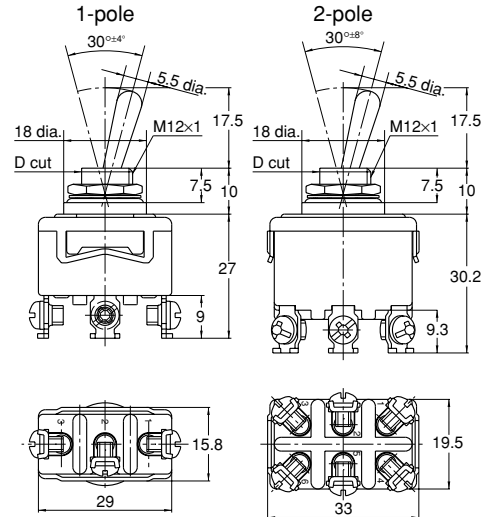

Remark: ON-OFF type does not have terminal No. 2 and 5.

3. Terminal-sealed type

1) Solder terminal

CAD Data

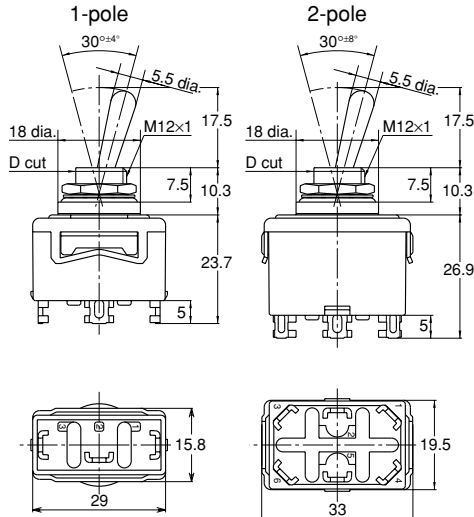

2) Screw terminal (M3.5)

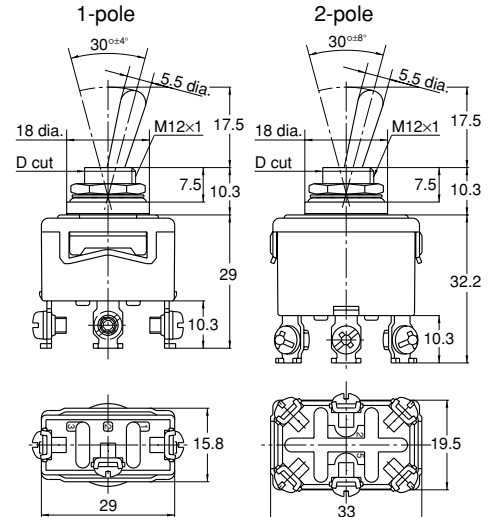

Remark: ON-OFF type does not have terminal No. 2 and 5.

4. Wire leads type

CAD Data

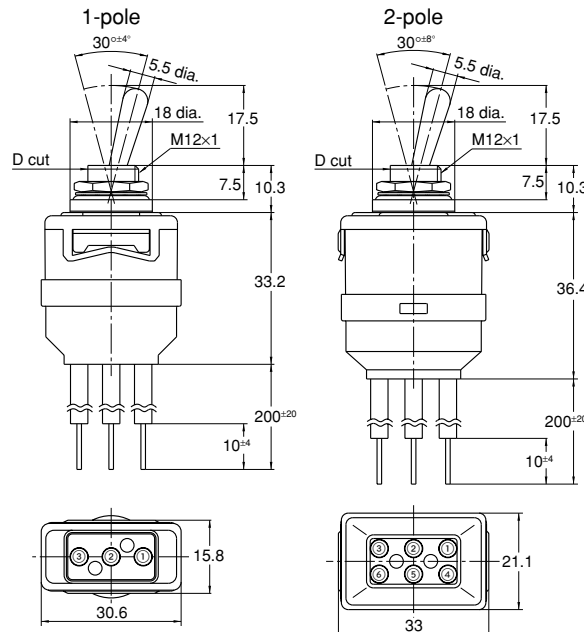
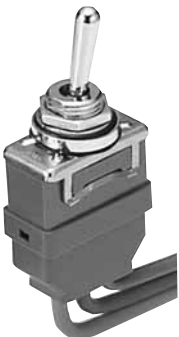

Color of wire leads

No.	Color
①	Brown
②	Red
③	Orange
④	Yellow
⑤	Green
⑥	Blue

Remarks: 1. ON-OFF type does not have wire lead No. 2 and 5.  
 2. 600 V vinyl wire (VSF, thick: 2 mm<sup>2</sup>, length: 200 mm) is used. Please inquire about type and different length of lead wire.

# ROCKER TYPE DIMENSIONS (mm) (General tolerance: $\pm 0.5$ )

## 1. Standard type

### 1) Solder terminal

#### CAD Data

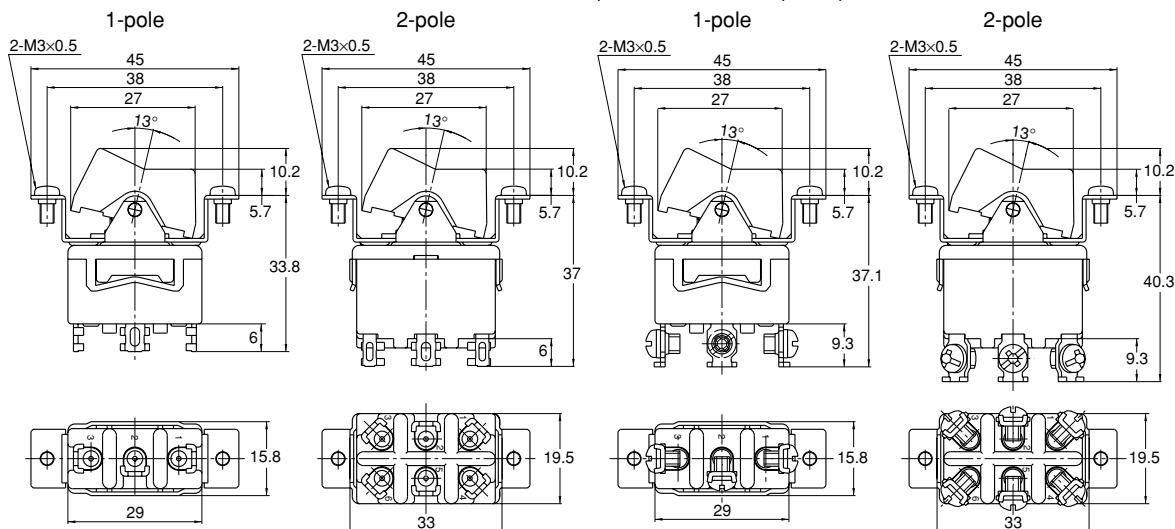

Remarks: 1. ON-OFF type does not have terminal No. 2 and 5.  
2. Dimensions of actuator:  $13.4 \times 27$

## 2. Panel-sealed type

### 1) Solder terminal

#### CAD Data

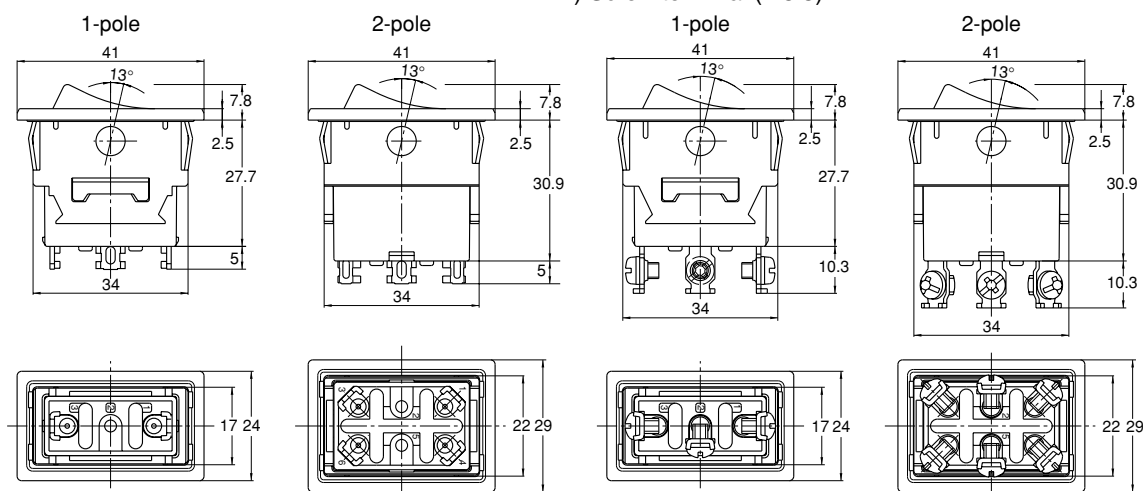

Remarks: 1. ON-OFF type does not have terminal No. 2 and 5.  
2. Dimensions of actuator: 1-pole:  $12.6 \times 29$ , 2-pole:  $17.4 \times 29$

## 3. Terminal-sealed type

### 1) Solder terminal

#### CAD Data

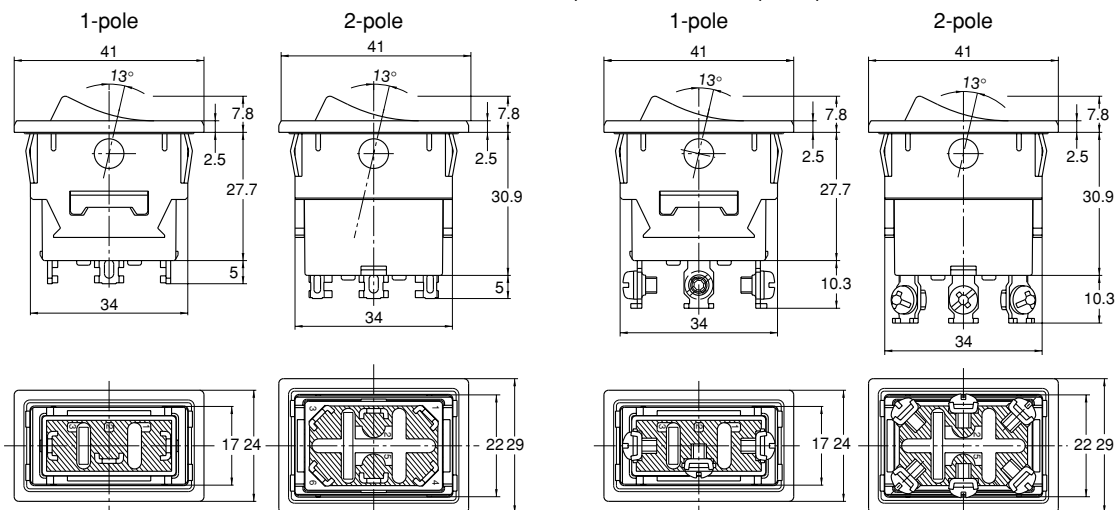

Remarks: 1. ON-OFF type does not have terminal No. 2 and 5.  
2. Dimensions of actuator: 1-pole:  $12.6 \times 29$ , 2-pole:  $17.4 \times 29$

4. Wire leads type

CAD Data



Remarks: 1. ON-OFF type does not have terminal No. 2 and 5.  
 2. Dimensions of actuator: 1-pole: 12.6 × 29, 2-pole: 17.4 × 29  
 3. 600 V vinyl wire (VSF, thick: 2 mm<sup>2</sup>, length: 200 mm) is used. Please inquire about type and different length of lead wire.

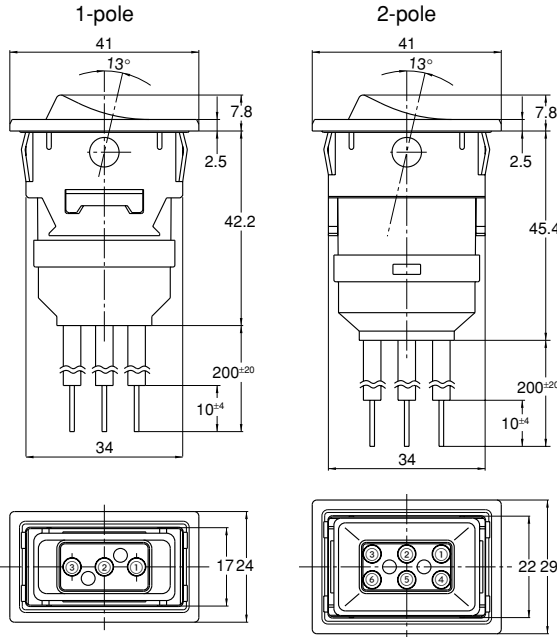

Color of wire leads

No.	Color
①	Brown
②	Red
③	Orange
④	Yellow
⑤	Green
⑥	Blue

PUSH-BUTTON TYPE DIMENSIONS (mm) (General tolerance: ±0.5)

1. Standard type

• Solder terminal, Momentary

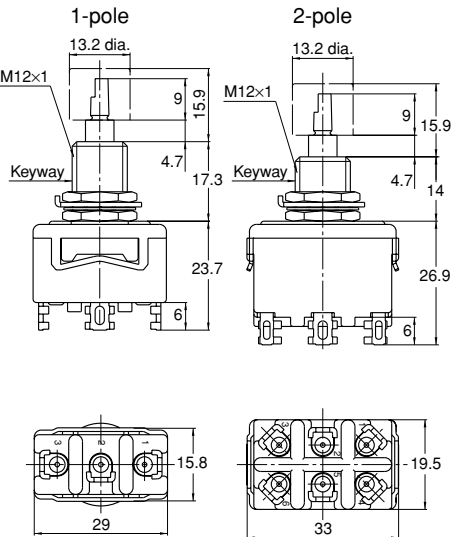

• Solder terminal, Alternate

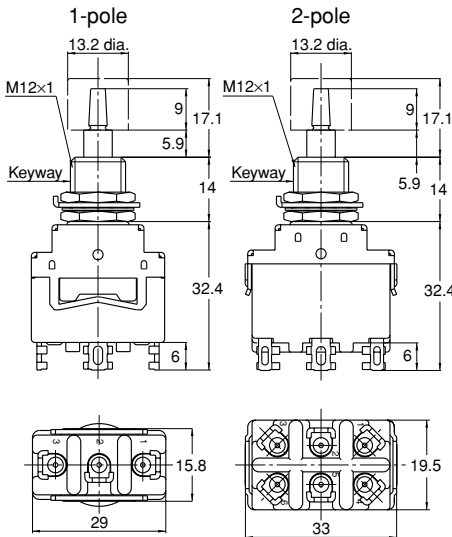

• Screw terminal (M3.5)

Dimensions other than listed below are same as those of solder terminal type.

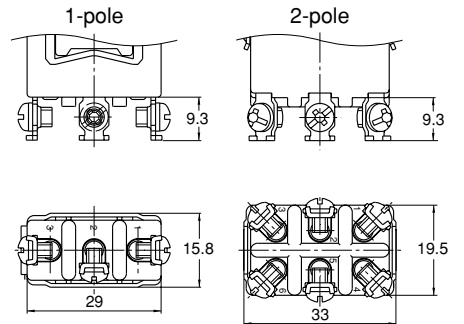

2. Panel-sealed type

• Solder terminal, Momentary

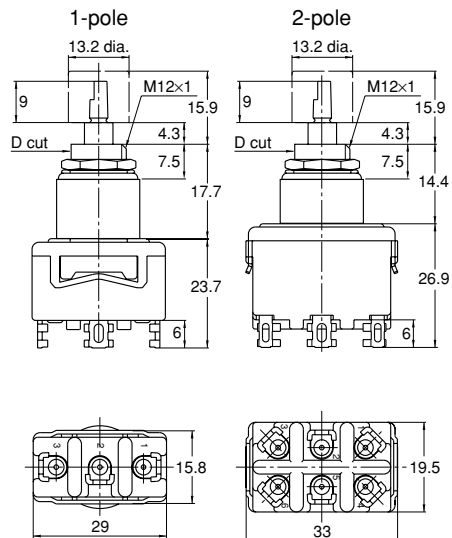

• Solder terminal, Alternate

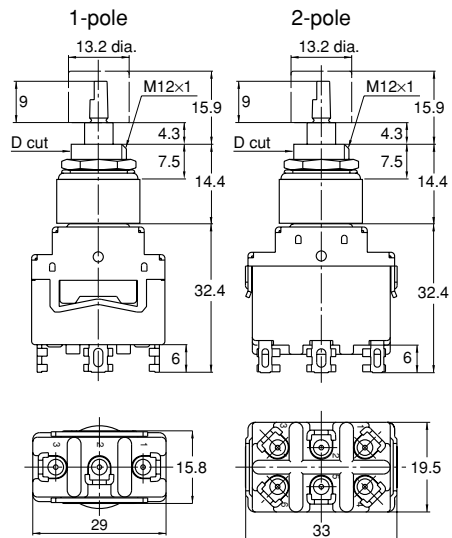

• Screw terminal (M3.5)

Dimensions other than listed below are same as those of solder terminal type.

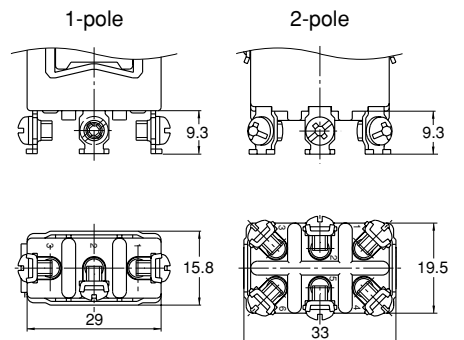

# MOUNTING DIMENSIONS

## 1. Toggle type

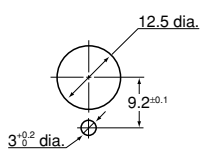
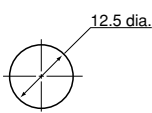
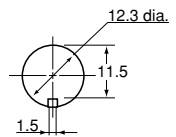

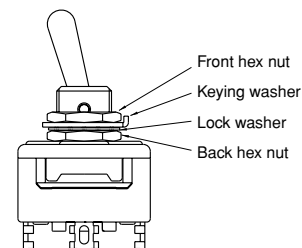
Type	Standard type		
Panel cutout (mm)			
Panel thickness	Max. 4.6 mm	Max. 5.6 mm (without keying washer)	Max. 5.6 mm (without keying washer)

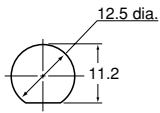
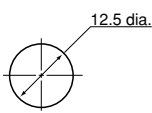

Type	Panel-sealed, Terminal-sealed and Wire leads types	
Panel cutout (mm)		
Panel thickness	Max. 4 mm	Max. 4 mm (without keying washer)

Remark: For panel installations of standard type, be use to use the back hex nut.

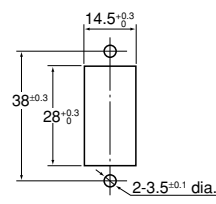
## 2. Rocker type

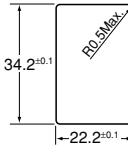
Type	Standard type	Panel-sealed, Terminal-sealed and Wire leads types
Panel cutout (mm)		<div style="display: flex; justify-content: space-around;"> <div style="text-align: center;"> <p>1 pole</p>  </div> <div style="text-align: center;"> <p>2-pole</p>  </div> </div>
Panel thickness	Max. 4.5 mm	1.2 to 3.2 mm



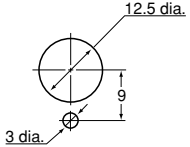
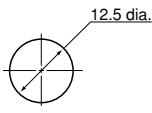
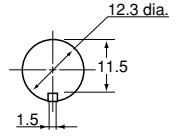
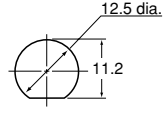
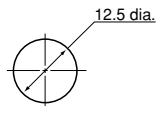







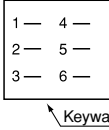
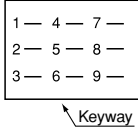
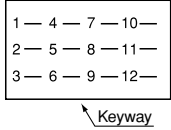



## 3. Push-button type

Type	Standard type			Panel-sealed type	
Panel cutout (mm)					
Panel thickness	Momentary, 1-pole: Max. 10 mm Momentary, 2-pole: Max. 6.5 mm Alternate: Max. 6.5 mm	Momentary, 1-pole: Max. 10 mm Momentary, 2-pole: Max. 7.5 mm Alternate: Max. 7.5 mm (without keying washer)	Momentary, 1-pole: Max. 11 mm Momentary, 2-pole: Max. 7.5 mm Alternate: Max. 7.5 mm (without keying washer)	Max. 4 mm	Max. 4 mm (without keying washer)

Remark: For panel installations of standard type, be use to use the back hex nut.

# ELECTRICAL CIRCUIT DIAGRAM

## 1. Toggle type and Rocker type



Number of pole				1-pole	2-pole	3-pole	4-pole	
Toggle type				Available	Available	Available *3	Available *3	
Rocker type				Available	Available	—	—	
Terminal arrangement (As seen from terminal side)								
Actuator position and contact terminal number	Actuator shape	Toggle type	Rocker type					
	ON-OFF	 Keyway		1-3	1-3, 4-6	1-3, 4-6, 7-9	1-3, 4-6, 7-9, 10-12	
		—	—	—	—	—	—	
		 Keyway		—	—	—	—	
	ON-ON ON-<ON> *1	 Keyway		2-3	2-3, 5-6	2-3, 5-6, 8-9	2-3, 5-6, 8-9, 11-12	
		—	—	—	—	—	—	
		 Keyway		1-2	1-2, 4-5	1-2, 4-5, 7-8	1-2, 4-5, 7-8, 10-11	
	ON-OFF-ON <ON>-OFF-<ON> ON-OFF-<ON> *1	 Keyway		2-3	2-3, 5-6	2-3, 5-6, 8-9	2-3, 5-6, 8-9, 11-12	
		 Keyway		—	—	—	—	
		 Keyway		1-2	1-2, 4-5	1-2, 4-5, 7-8	1-2, 4-5, 7-8, 10-11	
	Remarks				ON-OFF type does not have a terminal No. 2.	ON-OFF type does not have terminal No. 2 and 5.	ON-OFF type does not have terminal No. 2, 5 and 8.	ON-OFF type does not have terminal No. 2, 5, 8 and 11.

Remarks: \*1. For ON-<ON>, ON-OFF-<ON> type of toggle, if the lever turns to the keyway side, it takes momentary position.

\*2. For the rocker type, if the actuator turns to the left side in view of the side where a part number is marked, it takes momentary position.

\*3. Only standard type

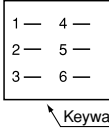
## 2. Push-button type

		1-pole	2-pole
Terminal arrangement (As seen from terminal side)			
Push-button position and contact terminal number		2-3	2-3, 5-6
	Operated 	1-2	1-2, 4-5



## NOTES

### 1. Dustproof, waterproof, anticorrosive gas, and oil-proof designs

The panel-sealed type/terminal-sealed type/wire lead type switch has a protection level of IP67 on the outer side of the mounting panel and a level of IP40, IP60, or IP67 on the inner side of the panel.

For actual application, note the following points:

1) Avoid immersion in water or oil during installation.

2) Avoid immersion in water or oil during operation.

3) Oils or gases impose varying degrees of impact on the switch's sealing performance depending on type or quantity.

4) While the switch has a immersion and dust-protected design, its sealing performance or operability may be adversely affected in an environment where in the switch's movable parts can be contaminated with dust, oil, or other foreign objects. For the toggle type, use of a rubber cap is recommended.

5) The standard toggle switch, when used with a rubber cap, provides a protection level of IP54.

It should be used in an environment where it will not be subject to frequent water splashes.

6) As the sealing performance of the rocker type switch is affected by the panel processing accuracy or mounted panel thickness, check the switch under actual loading conditions. (While water or dust will not enter the switch's internal structure, it may enter the panel.)

7) Do not operate the rocker type switch when water accumulates in the actuator.

### 2. Installation

1) For the toggle and push-button type  
a. When installing the standard type switch, be sure to use a hex nut.

b. For the panel-sealed, terminal-sealed and wire lead types, use a lock washer on the front side of the panel, and an O-ring on the back side of it.

c. Do not install the switch by rotating it.

2) For the rocker type

a. In case the panel-sealed, terminal-sealed or wire leads types are used in the condition where the water splash on, please install the switches tilt more than 25°. (90° recommended)

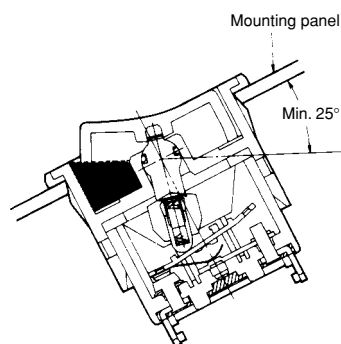

b. In case water inside the switch case may freeze, please install the switch vertically to avoid the water remain inside the switch.

3) Rubber cap installation

a. The washer should be used on the back side of the panel.

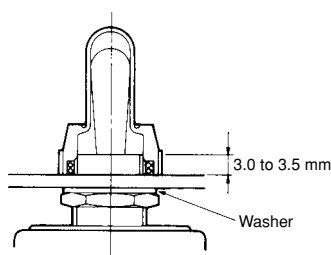

b. Enough screw pitch should be obtained being adjusted within 3 to 3.5mm (See figure above.)

c. Install a rubber cap on the switch knob before securing the switch with the hex nut.

d. The mounting hole in the panel should preferably be provided with an anti-rotation projection.

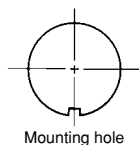

e. If the rubber cap is installed over the hex nut, the waterproof performance will be impaired although the dustproof performance will not be affected.

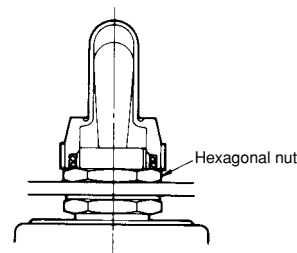

### 3. Soldering

1) By using 350°C soldering iron, soldering should be completed within 5 seconds.

2) Exercise care so as not to touch the switch body with a soldering iron.

### 4. Load type and ratings

1) When the switch is loaded with a lamp, motor or capacitive load, a surge current higher than the stationary current passes through the switch contacts.

Measure the surge with the actual load and, if needed, take necessary action so that the surge will not exceed the switch's rated current.

2) When the switch is loaded with an inductive load (relay, solenoid, buzzer, etc.), a contact failure may result from arc discharge caused by a counterelectromotive force. It is advisable that you use an adequate anti-spark circuit across the switch contacts.

### 5. Others

1) Do not apply an excessive static load exceeding 112.7N {11.5kgf} perpendicular to the direction of operation.

2) Operate the switch knob by hand.

3) Take care not to drop the product as it may impair performance.

Distributor: Sider Electronic Industries Ltd.  
Tel: 852-23892522 Fax: 852-23574546  
Email: info@sider.com.hk URL: www.sider.com.hk