



RoHS compliant

## FEATURES

- Realizes miniaturization of equipment and spaces saving. Size of body: 9.5×9.5×9.3 mm
- The contact type is equivalent to normally closed contacts, which satisfies the PL Act.
- The internal sphere can be used over an operation angle of 360 degrees in the circumferential direction.
- There are three standard terminal profiles which can be selected according to the mounting direction of the PCB.
- The terminals are tin-plated for long-term solderability.

## TYPICAL APPLICATIONS

- Gas heaters
- Electric fans
- Water vallet
- Infrared treatment device
- Electric pots with warming function

## ORDERING INFORMATION

Mounting direction Part No.	Vertical mounting AHF21	Horizontal mounting AHF22	Reverse mounting AHF23
PCB mounting condition			

Remark: Standard Packaging: Tube 50 pcs.

## CONTACT TYPE

Normally closed type (The photo transistor is ON when the sensor is being used.)

## APPLICABLE CIRCUIT

Refer to the dimensional diagram for the terminal Nos.

- $V_{CC} = 5\text{ V}$
- $R_2 = 100\text{ k}\Omega$
- Forward current,  $I_F$  of the LED: 19 mA  
( $V_{CC} = 5\text{ V}$ ,  $R_1 = 200\ \Omega$ )
- Forward voltage,  $V_F$  of the LED: Typ = 1.2 V

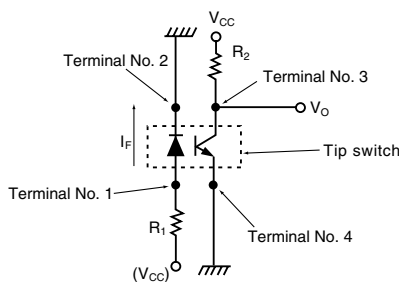

## BASIC CHARACTERISTICS

For  $T_a = 25^\circ\text{C}$  and applicable circuit conditions

- 1) Operation characteristics  
(Operation speed 6 degrees/second)
  - Operation angle (Output:  $V_{OL} \rightarrow V_{OH}$ ): 25 to 60 degrees
  - Return angle (Output:  $V_{OH} \rightarrow V_{OL}$ ): Min. 20 degrees

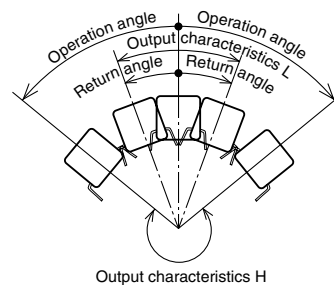

- 2) Output ( $V_O$ ) characteristics (The sphere must be stationary.)
  - $V_{OL}$  (photo transistor ON): Max. 1.0 V (horizontal)
  - $V_{OH}$  (photo transistor OFF): Min. 4.0 V (inclined at an angle of at least 60 degrees)

**Distributor: Sider Electronic Industries Ltd.**  
**Tel: 852-23892522 Fax: 852-23574546**  
**Email: info@sider.com.hk URL: www.sider.com.hk**

# SPECIFICATIONS

Item	Specifications
Electrical and mechanical life	Min. 10 <sup>5</sup> (Using the applicable circuit) At 6 cpm; Opening and closing position: 0 deg. ↔ 90 deg. (The internal sphere must be stationary for at least 500 ms at angles of 0 and 90 deg. respectively.)
Vibration resistance	10 to 400 Hz acceleration 2.9 m/s <sup>2</sup> applied for 7 days 5 to 10 Hz at half amplitude of 5 mm, 5×10 <sup>5</sup> cycles
Shock resistance	588 m/s <sup>2</sup> applied 3 times in each of 6 directions
Terminal strength	Min. 9.8 N (each direction)
Dropping individual part	Three times from height of 100 cm
High temperature, high humidity storage ability	Leave for 500 hours at 85°C and 85% RH (No freezing at low temperature)
High temperature storage ability	Leave for 500 hours at 85°C
Low temperature storage ability	Leave for 500 hours at -25°C (No freezing at low temperature)
Shock and heat resistance	Subject to 100 cycles each consisting of 30 minutes at -25°C and 30 minutes at 85°C.
Resistance to hydrogen sulfide	Leave for 500 hours in an atmosphere containing 3 ppm of hydrogen sulfide at 40°C and 75% RH.
Resistance to sulfur dioxide gas	Leave for 500 hours in an atmosphere containing 10 ppm of sulfur dioxide at 40°C and 95% RH
Resistance to ammonia gas	Leave for 96 hours in an atmosphere containing 3% of ammonia gas at normal temperature and humidity.
Resistance to dust	Mix with 2 kg/m <sup>3</sup> talcum powder or fly ash and leave to stand for 8 hours
Ambient temperature	-20 to +80°C (No freezing nor condensation at low temperature)

Notes:

1. Without any indications, specifications are measured at following conditions

- Temperature: 15 to 35°C
- Humidity: 25 to 85% RH
- Atmospheric pressure: 86 to 106 kpa.

2. The evaluation criteria for performance are as follows:

Basic characteristics – T<sub>a</sub> = 25°C and applicable circuit conditions

1) Operation characteristics (operation speed 6 degrees/sec.)

- Operation angle (Output: V<sub>OL</sub> → V<sub>OH</sub>): 25 to 60 degrees
- Return angle (Output: V<sub>OH</sub> → V<sub>OL</sub>): 20 degrees min.

2) Output (V<sub>o</sub>) characteristics (The sphere must be stationary.)

- V<sub>OL</sub> (photo transistor ON): 1.2 V max. (horizontal)
- V<sub>OH</sub> (photo transistor OFF): 3.8 V min. (inclined at an angle of at least 60 degrees)

# DIMENSIONS

The CAD data of the products with a **CAD Data** mark can be downloaded from: <http://industrial.panasonic.com/ac/e>

• Horizontal mounting type

**CAD Data**

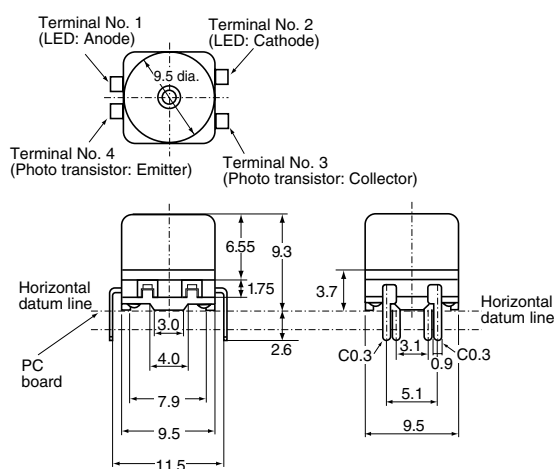

PC board pattern (Bottom view)

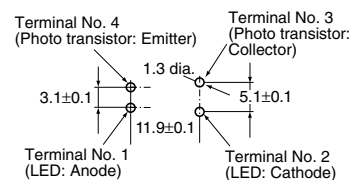

• Vertical mounting type

**CAD Data**

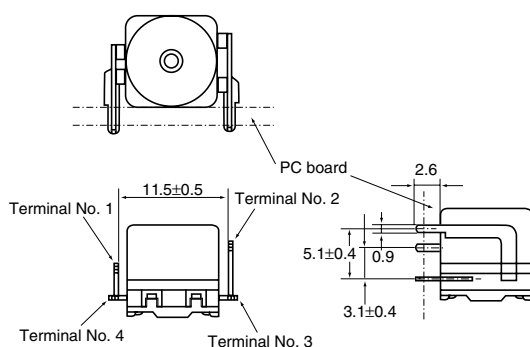

PC board pattern (Bottom view)

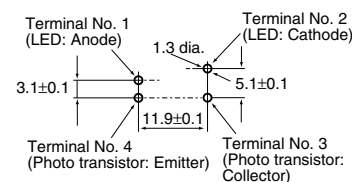

# AHF2

• Reverse mounting type

mm

## CAD Data

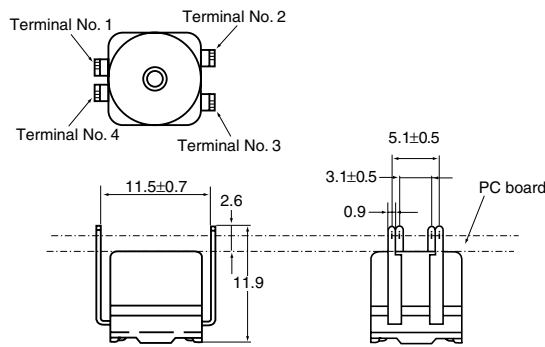

PC board pattern (Bottom view)

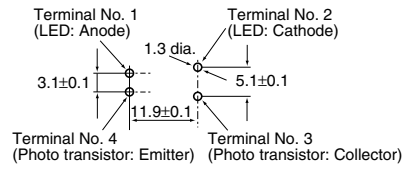

[Internal circuit and applicable circuit]

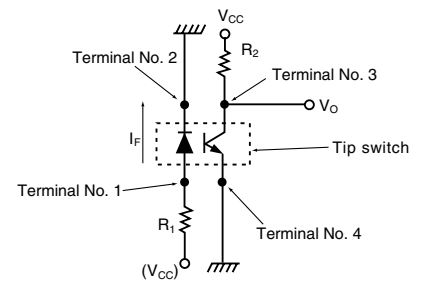

## NOTES

### 1. Handling

1) In the event that a voltage or current that exceeds the maximum rating is applied to, or passed between the terminals, the photo-transistor will no longer function normally. In such a case, do not reuse the photo-transistor but discard it.

2) Be careful not to apply an excessively large load to the terminals because this may damage the photo-transistor.

### 2. Soldering

1) When soldering by hand, use a 18W soldering iron that has a temperature regulator (iron tip temperature must be no more than 350°C) and apply the tip to the joint for no more than 3 seconds.

2) When performing automatic soldering, ensure that the board does not remain in the solder bath for more than 10 seconds at 260°C, or more than 3 seconds at 350°C.

3) Be careful not to move the terminals for one minute after soldering them.

### 3. Environment

This product is a non-contact type tip detection switch containing a photo-interrupter. It is intended for installation in equipment. Because of the nature of a semiconductor, if this product is used continuously for a long period in a high temperature, low temperature and/or humid environment, according to the

optic quantities decrease of luminescent diode output characteristics may be significantly affected. In such a case, take suitable measures, such as inserting a comparator at the output side, to provide a greater degree of margin with respect to change in the output characteristics, and thereby improve the reliability of the product.

### 4. Preventing a malfunction

1) The tip sensor uses an internal sphere, hence chattering occurs if it is subjected to vibration or shock. To prevent chattering, continuously read pulses of 30 ms max. using a microprocessor, and set the microprocessor so that the switch goes L (ON) or H (OFF) if the output level exceeds 500 ms continuously. Also, take steps to keep induction and RF noise away from the sensor.

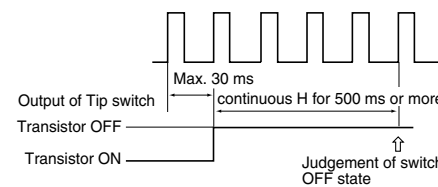

2) The switch should be mounted keeping away from the vibration generator such as motor. Fix the PC board firmly in order to prevent resonance with the vibration generator, or the contact chattering of a switch may occur by the movement of a

ball inside. The allowable vibration level which the chattering does not occur would be less than {0.3G} at 10 to 260Hz and 320 to 400Hz. The range 260 to 320Hz may have a resonance point and the level should be less than 0.1G.

### 5. Others

1) Depending on the circuitry and the environmental conditions, solder migration may occur and short a circuit. Please confirm that the insulation distance is large enough in the actual application.

2) To prevent a malfunction, the switch should be kept away from the direct sunlight and any other light sources.

3) The noises caused by electrostatics, surge voltage and inductives may break the photo-interrupter.

4) The reflow soldering and cleaning are not allowed.

5) The switch should be mounted with the tolerance  $\pm 3$  degree.

### 6. Confirmations in the actual use.

Each items in this spec sheet was tested and confirmed independently at a certain duration. To get a higher reliability of the equipment, please confirm the switch quality with the actual load and environmental conditions before using.