

General Specifications

Toggle

Rockers

Pushbuttons

Illuminated PB

Programmable

Keylocks

Rotaries

Slides

Tactiles

Tilt

Touch

Indicators

Accessories

Supplement

Electrical Capacity (Resistive Load)

Switching Rating: 25mA @ 24V DC
Nonswitching Rating: 0.1A @ 50V DC

Other Ratings

	JS02 Extended Actuator	JS04 Flush Actuator
Contact Resistance:	50 milliohms maximum	50 milliohms maximum
Insulation Resistance:	100 megohms minimum @ 500V DC	100 megohms minimum @ 100V DC
Dielectric Strength:	500V AC minimum for 1 minute minimum	300V AC minimum for 1 minute minimum
Mechanical Life:	2,000 operations minimum	2,000 operations minimum
Electrical Life:	2,000 operations minimum	2,000 operations minimum
Total Travel:	.031" (0.8mm)	.026" (0.65mm)

Materials & Finishes

	JS02 Extended Actuator	JS04 Flush Actuator
Actuator:	Glass fiber reinforced polyamide	Glass fiber reinforced polyamide
Cover:	Glass fiber reinforced polyamide (UL94V-0)	Glass fiber reinforced polyamide (UL94V-0)
Base:	Glass fiber reinforced polyamide (UL94V-0)	Glass fiber reinforced polyamide (UL94V-0)
Contacts:	Beryllium copper with gold plating	Copper alloy with gold plating
Terminals:	Brass with gold plating	Brass with gold plating

Environmental Data

Operating Temp Range: **JS02 Extended Actuator:** -20°C through +70°C (-4°F through +158°F)
JS04 Flush Actuator: -30°C through +85°C (-22°F through +185°F)

Humidity: 90 ~ 95% humidity for 96 hours @ 40°C (104°F)

Vibration: 10 ~ 55Hz with peak-to-peak amplitude of 1.5mm traversing the frequency range & returning in 1 minute; 3 right angled directions for 2 hours

Shock: 50G (490m/s²) acceleration (tested in 6 right angled directions, with 5 shocks in each direction)

PCB Processing

Soldering: Reflow Soldering Recommended. See Profile A in Supplement section.
 Manual Soldering: See Profile A in Supplement section.
 Note: Switches are packaged in OFF position and should be soldered in OFF position.

Cleaning: These devices are not process sealed. Hand clean locally using alcohol based solution.

Standards & Certifications

Flammability Standards: UL 94V-0 rated cover & base
 The JS Series slides have not been tested for UL recognition or CSA certification. These switches are designed for use in a low-voltage, low-current circuit. When used as intended in a low-voltage, low-current circuit, the results do not produce hazardous energy.

Distinctive Characteristics

Extended and flush slide actuators available.

Twin sliding contact mechanism with self-cleaning action (JS02) provides smooth actuation and produces high contact reliability.

Gold plated contacts prevent oxidation and sulfide effect and provide stable contact resistance.

Use of self-extinguishing UL94V-0 certified material in cover and base provides high arc resistance and high insulation resistance.

Gull-wing terminals ensure secure PCB mounting and prevent dislodging during vapor phase and infrared convection reflow soldering.

Terminal spacing conforms to standard PCB grid.
 For JS02: .100" (2.54mm)
 For JS04: .050" (1.27mm)

End-to-end stackable.

Packaged in tape-reel or stick-tube. Tape-reel packaging meets EIA-481-2 Standard.

Coplanarity: all considered surfaces must lie between two parallel planes that are a maximum distance apart of .0059" (0.15mm). (Additional coplanarity details in Terms and Acronyms in the Supplement section.)

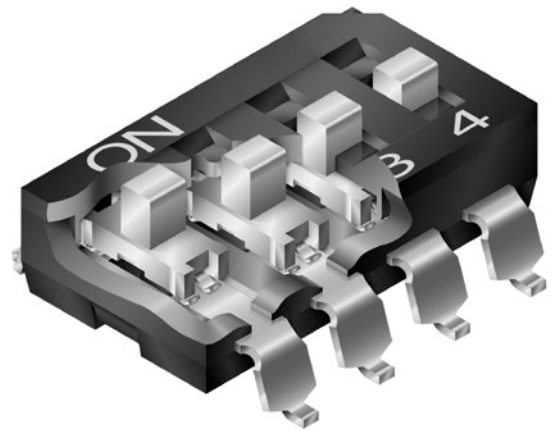

Actual Sizes

JS02



JS04



- Toggles
- Rockers
- Pushbuttons
- Illuminated PB
- Programmable
- Keylocks
- Rotaries
- H Slides**
- Tactiles
- Tilt
- Touch
- Indicators
- Accessories
- Supplement

TYPICAL SWITCH ORDERING EXAMPLE

JS

02

08

A

P4

S

Mounting

02	SMT .100" (2.54mm) for Extended Actuator
04	SMT .050" (1.27mm) for Flush Actuator

Actuator

A	Extended for 02 Mounting Code
F	Flush for 04 Mounting Code

Packaging

S	Stick-Tube
R	Tape-Reel
Not available in bulk	

No. Of Positions

04	4 Positions
08	8 Positions

Contact Material & Rating

P4	Gold Rated 25mA @ 24V DC
----	-----------------------------

DESCRIPTION FOR TYPICAL ORDERING EXAMPLE

JS0208AP4-S

Extended Slide Actuator, 8 Positions

.100" (2.54mm) Terminal Spacing

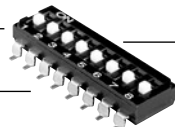

SPST OFF-ON Circuit

Gold Contacts with 25mA Rating

Stick-Tube Packaging

TYPICAL SWITCH DIMENSIONS

Single Pole

4 Positions • Extended Actuator

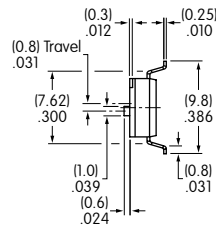
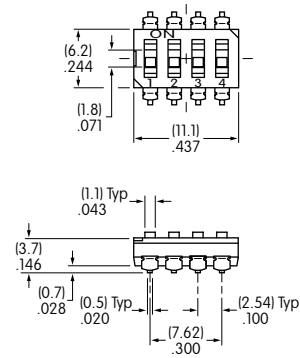

End View

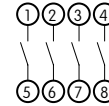
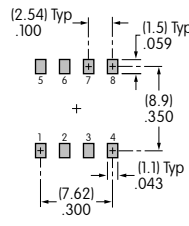

Schematic

JS0204AP4

Single Pole

8 Positions • Extended Actuator

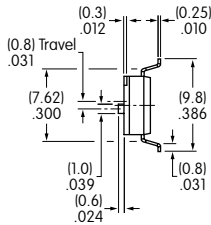
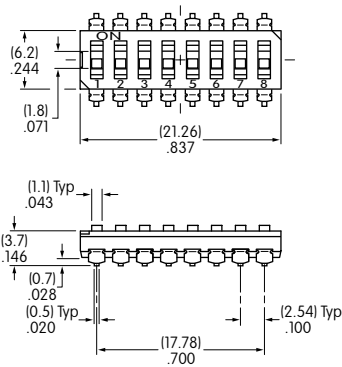

End View

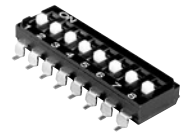
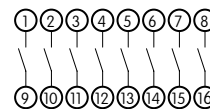
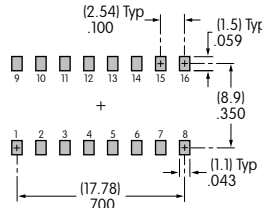

Schematic

JS0208AP4

Single Pole

4 Positions • Flush Actuator

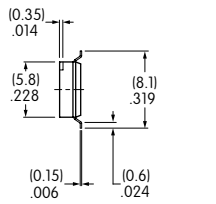
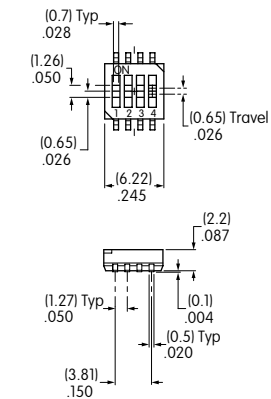

End View

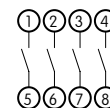
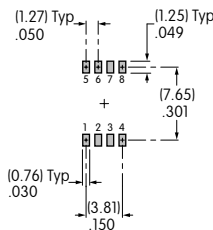

Schematic

JS0404FP4

Single Pole

8 Positions • Flush Actuator

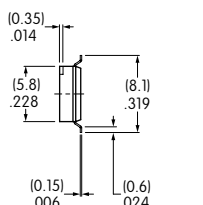
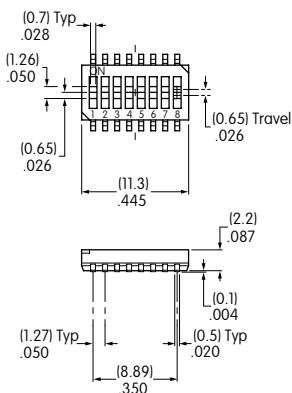

End View

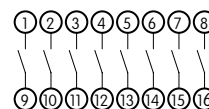
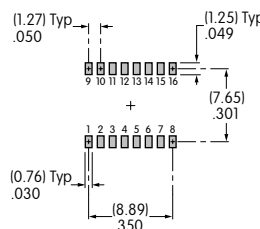

Schematic

JS0408FP4

PACKAGING

S

Stick-Tube Packaging

Switches are packaged in OFF position.
Switches are not available in bulk and must be ordered in the following increments:

Extended Actuator

JS0204AP4-S: 46 pieces per stick-tube
JS0208AP4-S: 24 pieces per stick-tube

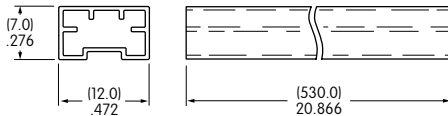

Flush Actuator

JS0404FP4-S: 80 pieces per stick-tube
JS0408FP4-S: 45 pieces per stick-tube

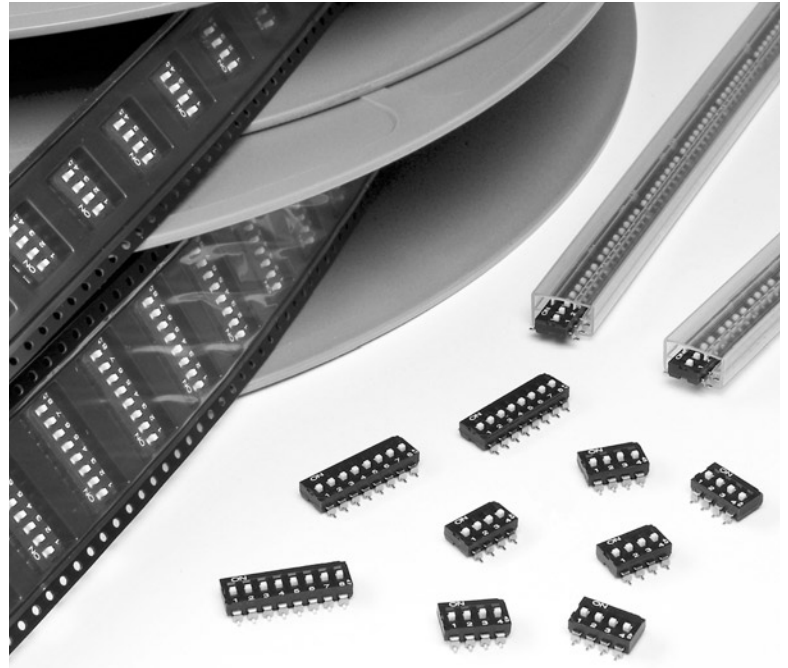
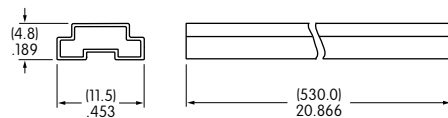

R

Tape-Reel Packaging for Extended Actuator

Switches are packaged in OFF position.
Switches are not available in bulk and must be ordered in the following increments:

JS0204AP4-R: 500 pieces per tape-reel
JS0208AP4-R: 500 pieces per tape-reel

Minimum Leader Length: 15.75" (400mm)
Minimum Trailer Length: 6.3" (160mm)

Tape-reel packaging meets EIA-481-2 Standard.

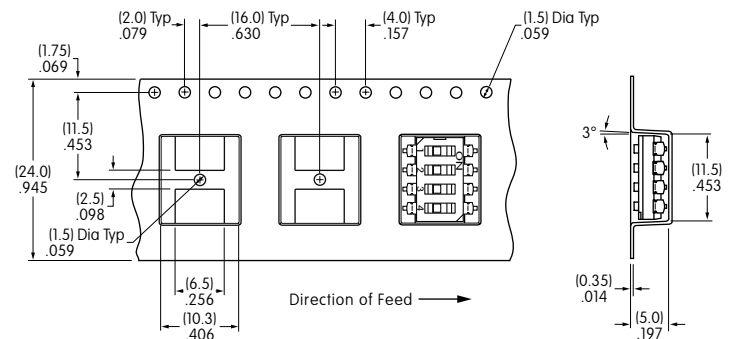

Tape Dimensions for JS0204AP4-R

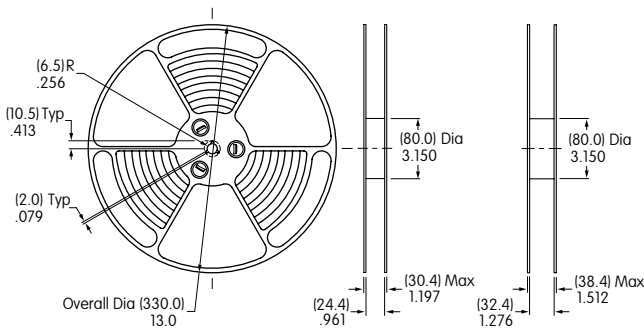

Reel Dimensions JS0204AP4-R JS0208AP4-R

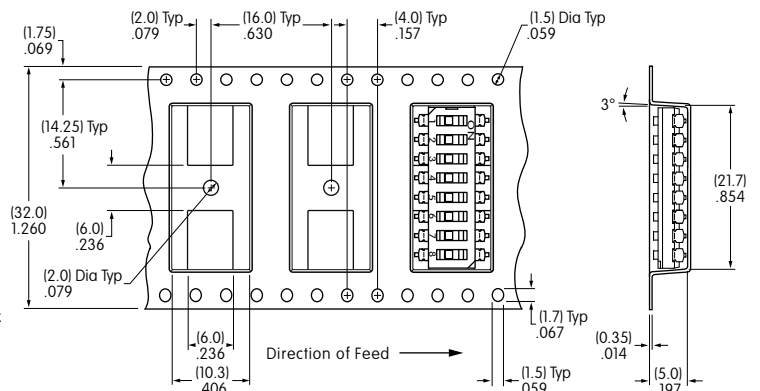

Tape Dimensions for JS0208AP4-R

PACKAGING (CONTINUED)

R

Tape-Reel Packaging for Flush Actuator

Switches are packaged in OFF position.
Switches are not available in bulk and must be ordered in the following increments:

- JS0404FP4-R: 2,000 pieces per tape-reel
- JS0408FP4-R: 2,000 pieces per tape-reel

Minimum Leader Length: 15.75" (400mm)
Minimum Trailer Length: 6.3" (160mm)

Tape-reel packaging meets EIA-481-2 Standard.

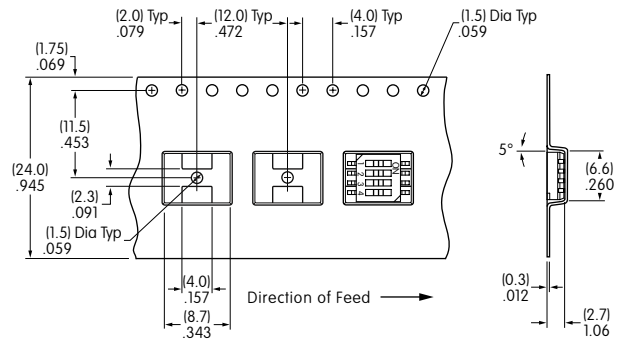

Tape Dimensions for JS0404FP4-R

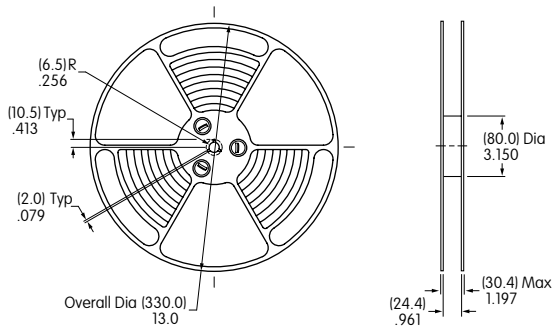

Reel Dimensions for JS0404FP4-R & JS0408FP4-R

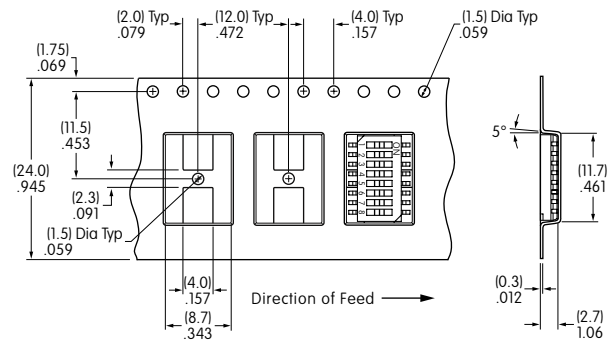

Tape Dimensions for JS0408FP4-R

Toggles

Rockers

Pushbuttons

Illuminated PB

Programmable

Keylocks

Rotaries

H Slides

Tactiles

Tilt

Touch

Indicators

Accessories

Supplement